

SAFE GUN HANDLING

You should be fully familiar with the proper and safe handling with your Airsoft gun. The basic principles of gun safety require you to always apply the following rules when handling an Airsoft gun.

您必須完全了解玩具槍正確的操作以及安全守則。

為了您使用上的安全，你必須遵循以下的各項規則。

Always wear eye protective gear.

始終配戴護目鏡

You may be punished if you are shooting for practical jokes.

若隨意用玩具槍開玩笑可能會觸及法律

Never shoot the gun at places where people and cars pass cross.

切勿在有人及汽車經過的地方開槍

Never aim or shoot a person or animal as a target.

切勿將人或動物做為目標射擊

Never look into the gun muzzle.

切勿直視槍口

Always direct the muzzle towards a safe direction.

始終將槍口朝向安全位置

Avoid pulling the trigger carelessly.

避免不小心拉動扳機

Please put away from your fingers from the trigger, except when you are ready to shoot a target.

除準備射擊目標外，請不要將手指放在扳機上

Always put the gun in a case or bag when you are carrying it.

攜帶槍枝時請將其放在箱子或袋子中

Keep out of reach of children.

請將本品放在兒童無法觸及的地方

DO NOT ATTEMPT TO DISASSEMBLE OR TAMPER WITH YOUR AIRSOFT GUN. CONTACT CUSTOMER SERVICE AT VFC FOR REPAIR.

請勿嘗試拆卸或變造玩具槍。有維修需求時，請聯絡VFC的客戶服務進行維修。

⚠ WARNING: DO NOT BRANDISH OR DISPLAY THIS AIRSOFT GUN IN PUBLIC-IT CONFUSE PEOPLE AND MAY BE A CRIME.POLICE AND OTHERS MAY THINK THIS AIRGUN IS A FIREARM.DO NOT CHANGE THE COLORATION AND MARKINGS TO MAKE IT LOOK MORE LIKE A FIREARM. THIS IS DANGEROUS AND MAY BE A CRIME.

請勿在公共場所揮舞或展示玩具槍，以免造成他人困擾及恐慌，警察與其它民眾可能會認為玩具是真槍，並可能構成犯罪行為。請勿變造玩具槍的外觀與機構，使玩具槍更像真槍，此為非法行為。

⚠ CAUTION:
EYE PROTECTION
REQUIRED
WEAR YOUR
SHOOTING GLASSES

請注意
眼睛的保護

並於射擊時
戴上護目鏡



VegaForce Company

<https://www.vegaforce.com/>

8F., No. 609, Sec. 1, Wanshou Rd.,
Guishan Dist., Taoyuan City 333, Taiwan

Phone:+886-2-8200-6630

Fax:+886-2-8200-6610

E-Mail:service@vegaforce.com.tw

Your Dealer

Ver. 202007

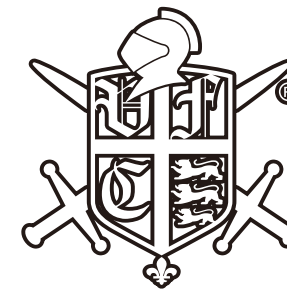

MOD. VR16 / M4 SERIES

Cal. 5.95mm Airsoft Electric Rifle

HANDLING CAUTIONS AND INSTRUCTION MANUAL

MANUFACTURED BY VEGA FORCE COMPANY MADE IN TAIWAN

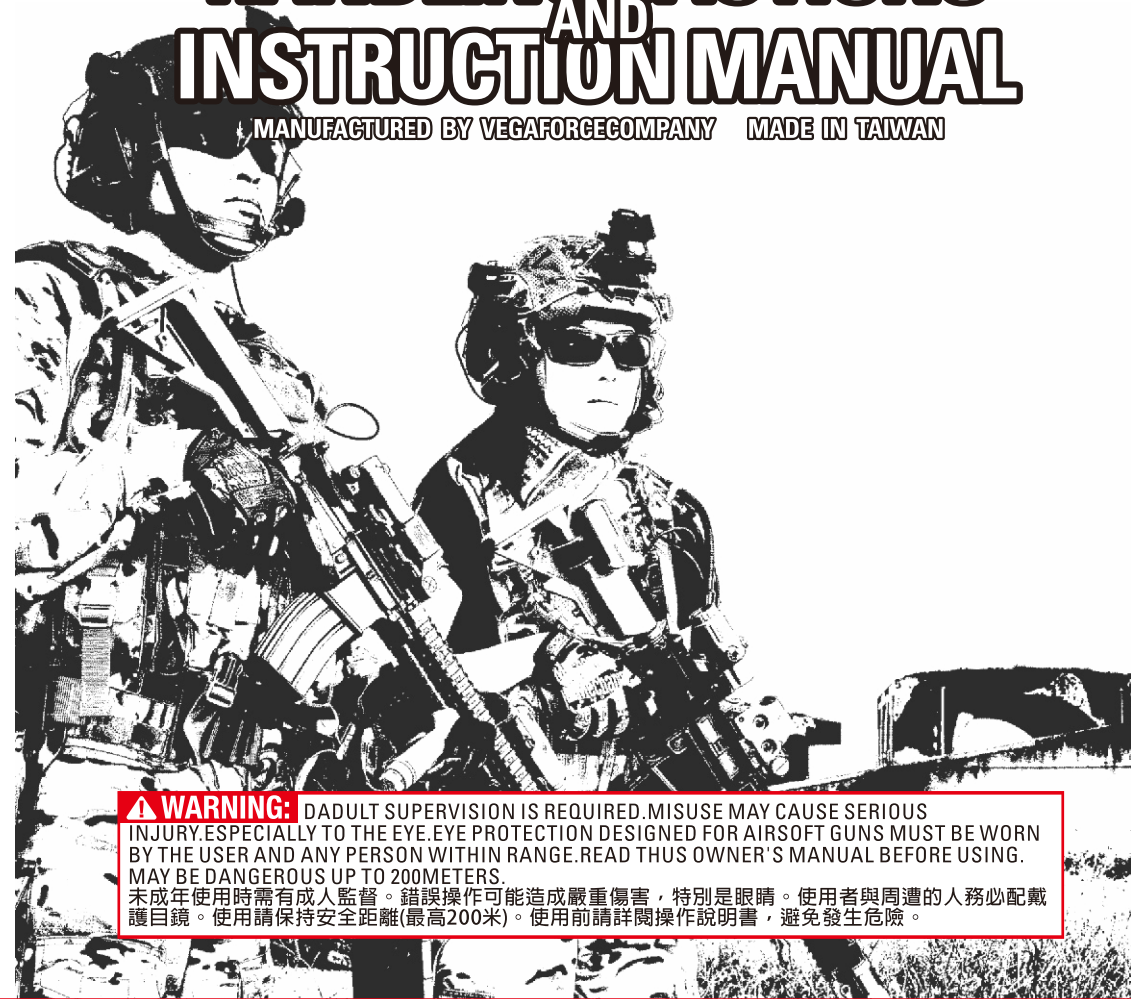

⚠ WARNING: ADULT SUPERVISION IS REQUIRED.MISUSE MAY CAUSE SERIOUS INJURY.ESPECIALLY TO THE EYE.EYE PROTECTION DESIGNED FOR AIRSOFT GUNS MUST BE WORN BY THE USER AND ANY PERSON WITHIN RANGE.READ THUS OWNER'S MANUAL BEFORE USING. MAY BE DANGEROUS UP TO 200METERS.

未成年使用時需有成人監督。錯誤操作可能造成嚴重傷害，特別是眼睛。使用者與周遭的人務必配戴護目鏡。使用請保持安全距離(最高200米)。使用前請詳閱操作說明書，避免發生危險。

HISTORY OF VEGA FORCE COMPANY

Vega Force Company was founded by the people who love guns in 2004. The VFC founders believe that guns are "Works of Art". VFC uses its expertise to produce highly realistic Airsoft replica with custom grade performance of internal mechanical design, which allows VFC users to have better shooting and operating experience. What's more than that is every VFC Airsoft product is in the standard of collection grade with strong and refined surface finishing. "Collectors wanted and operators wanted" is the motto for VFC's products.

Vega Force Company由熱愛槍械的人於2004年成立。VFC創始人認為，槍械是種“藝術品”。VFC利用其專業知識生產性能與外觀高度逼真的玩具槍，從而使VFC用戶可以獲得更好的射擊與操作體驗。不僅如此，所有VFC玩具槍產品都達到了收藏級的標準，並具有堅固而精緻的表面處理。VFC的座右銘是“收藏家與玩家皆想擁有”。

The reputation VFC earned is not only from the users, but also from distributors and license holders around the world. With OEM experience of more than a decade, VFC's team of professionals specializes in designing and developing quality Airsoft products.

VFC贏得的聲譽不僅來自用戶，而且還來自全球的經銷商和授權商。VFC的專業團隊擁有超過十年的OEM經驗，專門設計與開發高品質的玩具槍產品。

The VR16 series is one of the most unique products in VFC. It is distributed around the world, earned a good reputation and market response. It is combined with high-end technology and excellent quality to achieve and reach the high-end Airsoft AEG range. All the details and designs are amazing. It is simply reaching for the best.

VR16系列是VFC中最獨特的產品之一。它銷售至世界各地，贏得了良好的聲譽和市場反應。結合了高端技術和卓越的品質，以達到高階電動玩具槍系列的價值。所有的細節和設計都很棒，只為了追求更好。

VR16 / M4 Series Features

The VFC VR16 series comes with full metal body, nice surface finishing and high quality VR16 engravings. The Internal of VR16 includes High-performance custom gearbox to let your rifle more powerful, and the MOSFET electronic control unit inside for higher efficiency and faster trigger response. Full of the QRS accessories allow you to adjust the rifle to fits your shooting motion. Dust cover can be flipped open to reveal hop-up adjuster, and VR16 also comes with an ambidextrous fire selector which is lefty friendly. VFC VR16系列帶有全金屬槍身，良好的表面處理和高品質VR16深刻。VR16的內構包括高性能的齒輪箱，使您的步槍更強勁；內部的MOSFET電子控制元件可提供更高的效率和更快的觸發響應。裝配QRS配件後，您就可以調整步槍以適合自己的射擊方式。防塵蓋可以掀開以便於直接調節hop-up系統，VR16還配備了雙邊運動的射擊選擇鈕，非常方便。

This series has the most popular rail system with ample room for all sorts of sights and accessories. Just like in real world, this makes things much easier when it comes to stabilizing yourself in each and every shot, same in the Airsoft world, and also for aesthetics.

這個系列具備最受歡迎的軌道系統，且擁有足夠的空間容納各種準照跟配件，就如同在現實世界般，這樣的系統讓穩定射擊變得容易，不論是在Airsoft玩具上或是及美學方面都極其擬真。

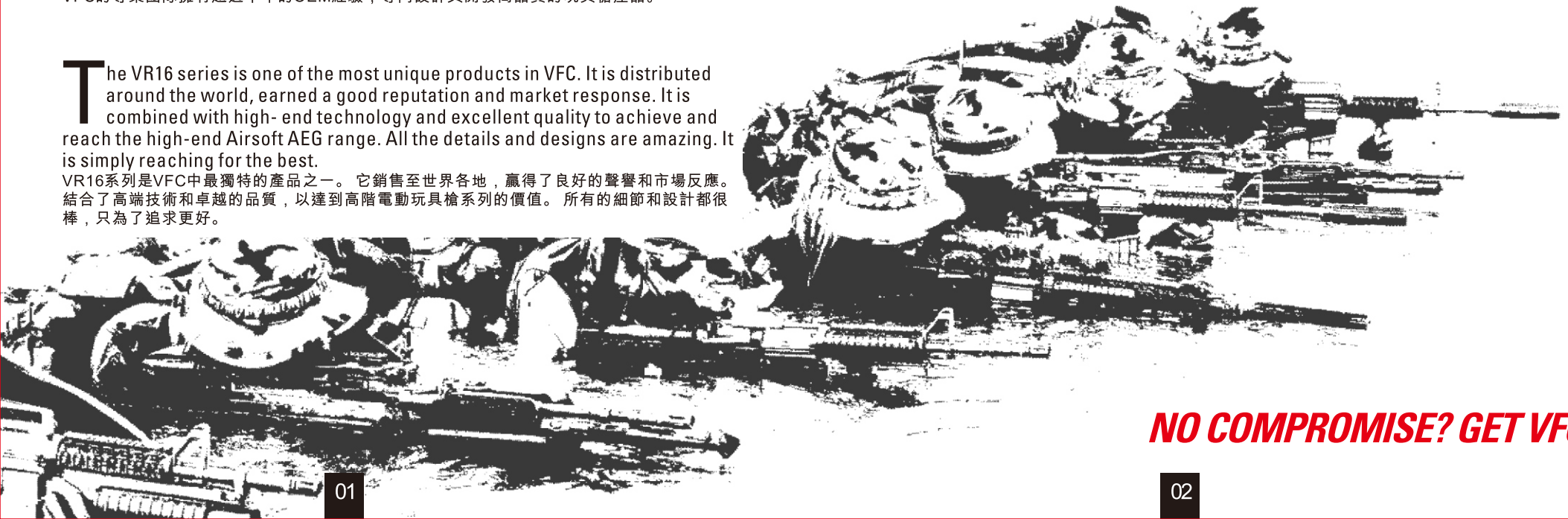

NO COMPROMISE? GET VFC!

COMPONENTS

RIGHT SIDE

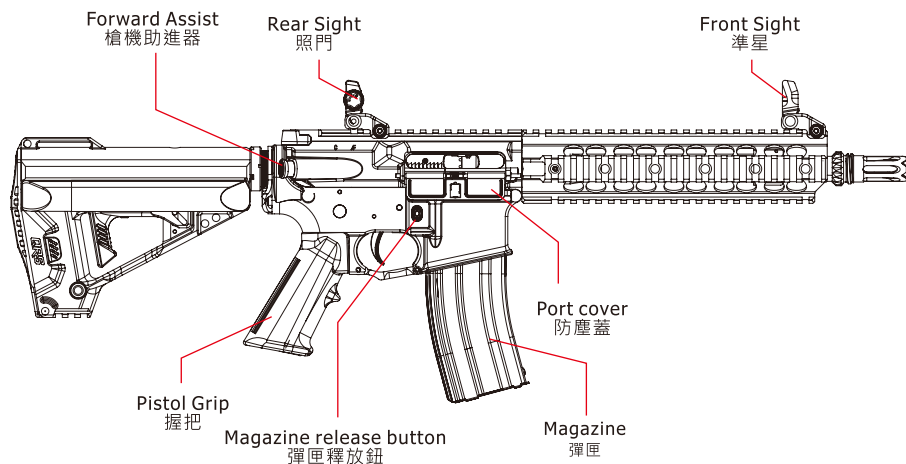

LEFT SIDE

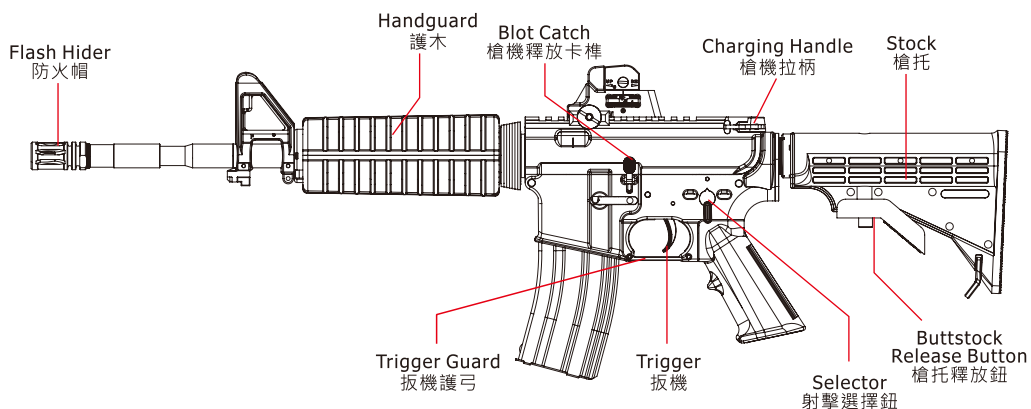

SAFETY SETTING

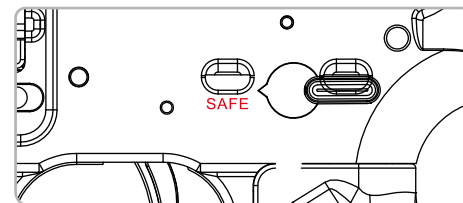

Safety Setting 保險位置
(The trigger can not be pulled)
無法扣動扳機

Always set lever to SAFE position when gun is not in use.
在未使用玩具槍的狀態下，
始終將射擊選擇鈕保持在保險位置。

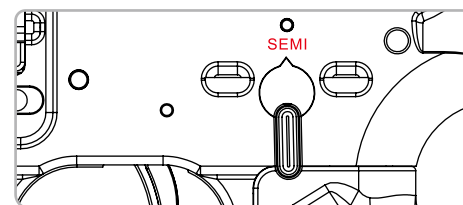

Semi Auto 半自動

Pulled the trigger,
the gun will fire one shot each time.
拉動一次扳機，則發射一發子彈

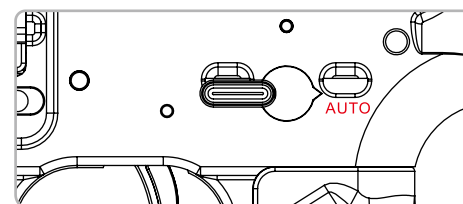

Full Auto 全自動

The gun will fire automatically
while the trigger remains pulled.
扣著扳機不放將連續發射子彈

WARNING · CAUTION

- Do not operate the selector lever while the trigger is depressed. Damage and malfunction will occur if you attempt to do so.
請勿在扣壓扳機的同時，切換射擊選擇鈕，這樣會造成玩具槍的故障。
- Do not pull the trigger while the selector is on SAFE. Doing so will damage the trigger and safety mechanisms.
當射擊選擇鈕處於保險狀態，請勿去拉動扳機，
這樣容易造成扳機與保險裝置的損壞。

INSTALLING BATTERY

WARNING · CAUTION

Before changing the battery, point the gun in a safe direction, remove the magazine, and set the selector to SAFE.
更換電池前，請將槍口朝項安全方向，射擊選擇鈕轉為保險模式，並將彈匣卸除。

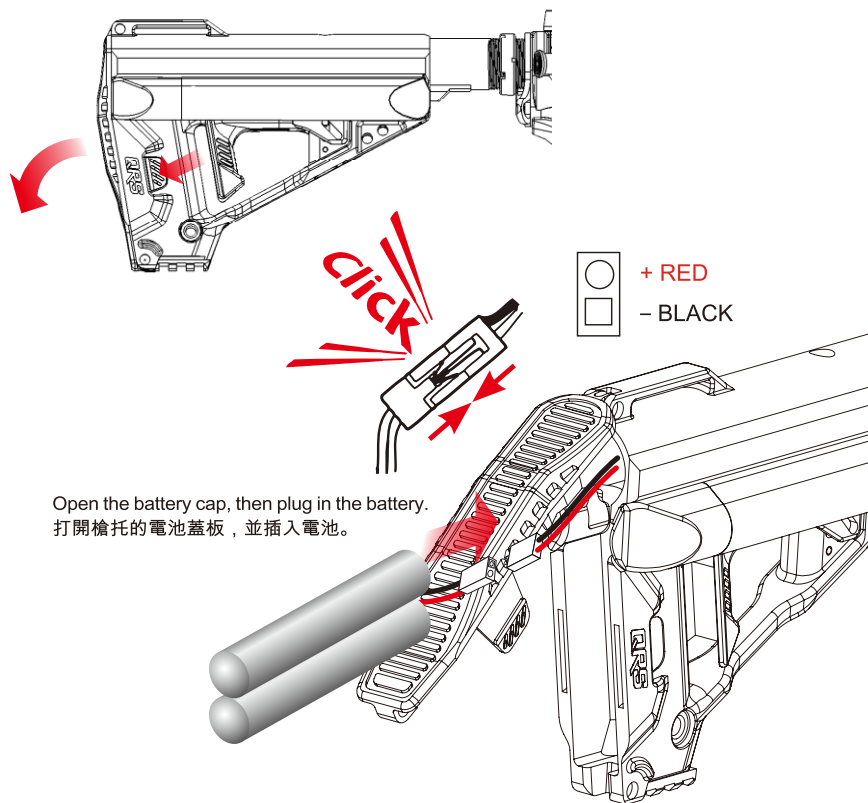

Open the battery cap, then plug in the battery.
打開槍托的電池蓋板，並插入電池。

CAUTION

When batteries have almost lost their charge they can cause gearbox malfunctions that require repair. Batteries should never be over-charged. This can damage the cell. Prolonged overcharging causes permanent damage to batteries. There is no warranty for batteries.

Use only those batteries of min. 9.6 V 3000mAh
當電池電量耗盡時，請盡速更換，避免造成齒輪箱故障。
請勿將電池過度充電。
長時間過度充電會造成電池永久損壞。
電池沒有提供保固。
建議使用 9.6 V 3000mAh 的電池。

LOADING MAGAZINE

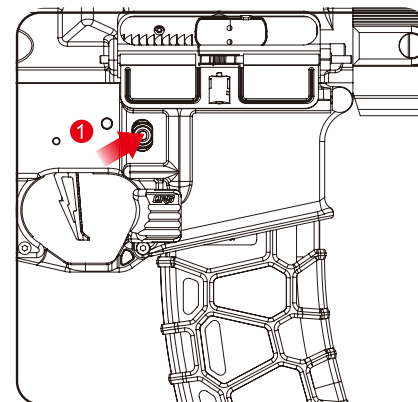

Use only 6mm BB
with the magazine.
彈匣只能使用 6mm 的 BB 彈

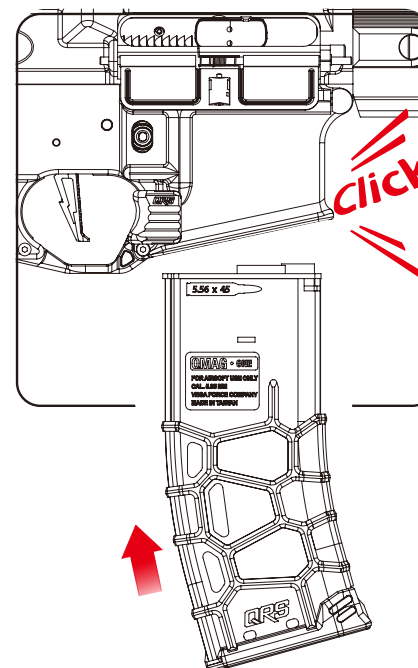

Press the magazine release button to remove the magazine.
按壓彈匣釋放鈕並卸除彈匣

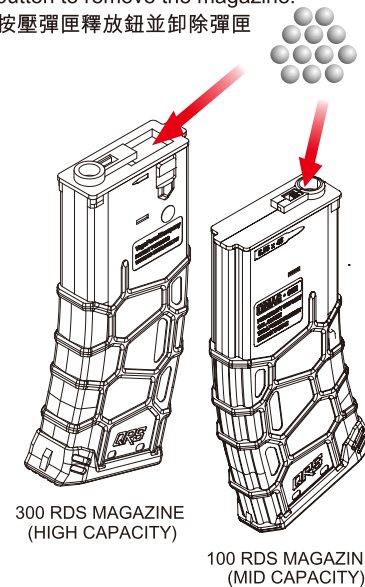

WARNING · CAUTION

- Always use high quality 0.20 gram or heavier BB in your airsoft rifle.
請使用高品質的 0.20 克或是更重的 BB 彈。

We will not be held responsible for any damage or incidents arising from use of poor quality or underweight BB. 對於因使用品質差或重量不足的 BB 彈造成的損壞，本公司概不負責。

Make sure to set the magazine upwards and connect it firmly until a click sound is heard.
將彈匣向上推入彈匣井內，確保彈匣插入方向正確。
向上插入直到聽到喀噠聲為止。

ADJUSTING SIGHTS

ADJUSTING SIGHTS 準星照門調整

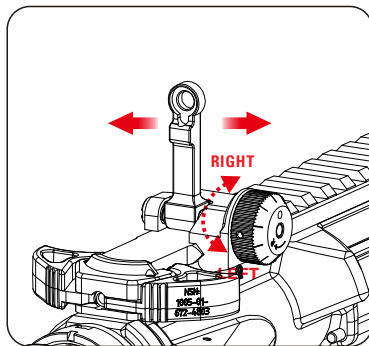
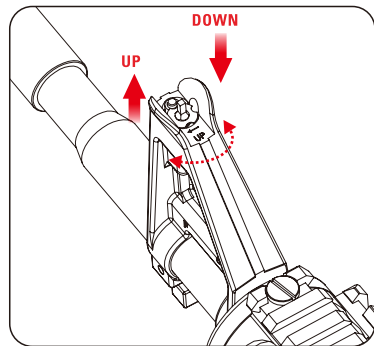
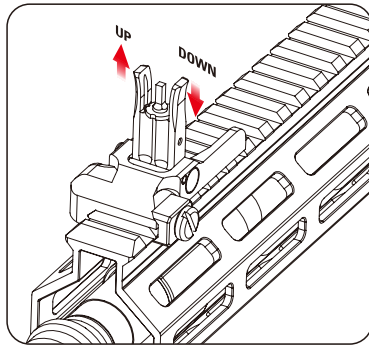
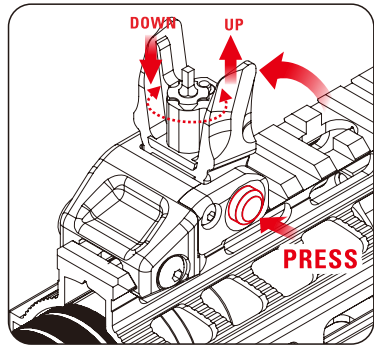

ADJUSTING SIGHTS 準星照門調整

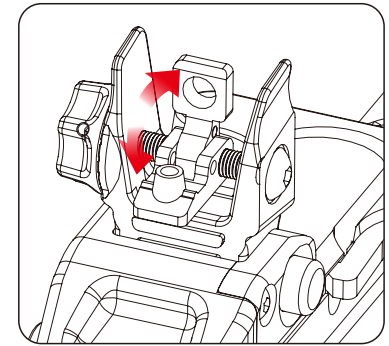
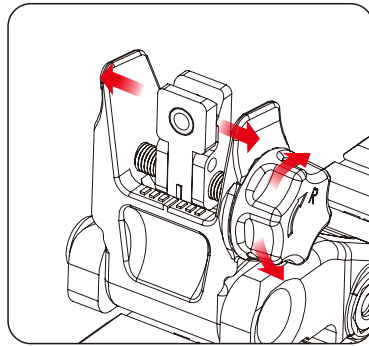
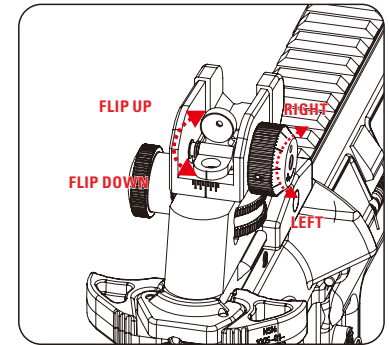
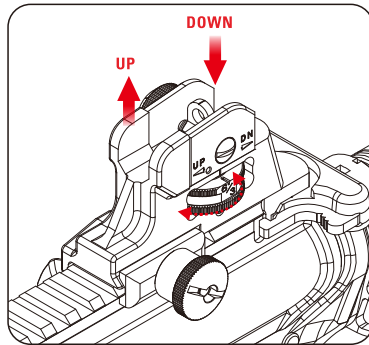
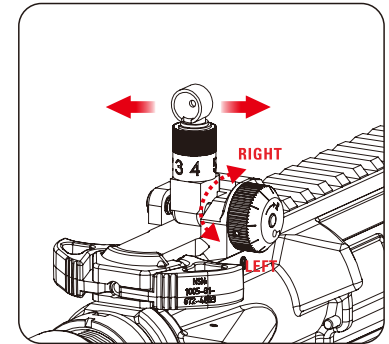
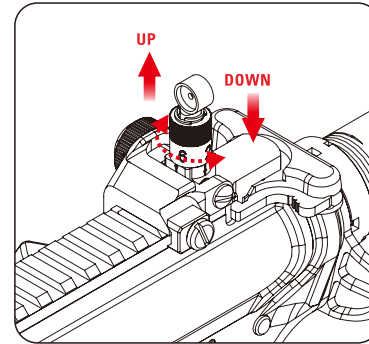

ADJUSTING THE QRF STOCK

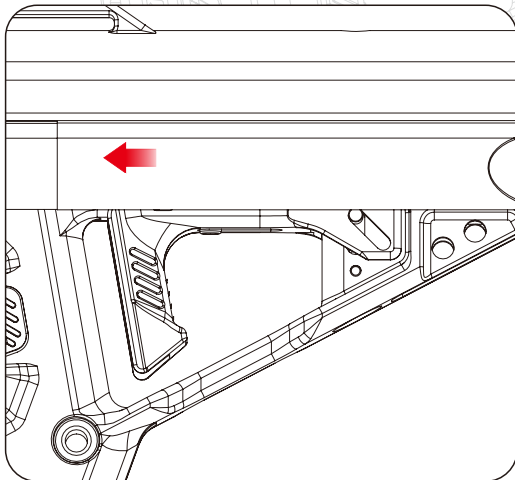

Press the stock release button,
then adjust the stock position.
按下槍托釋放鈕，調整槍托位置。

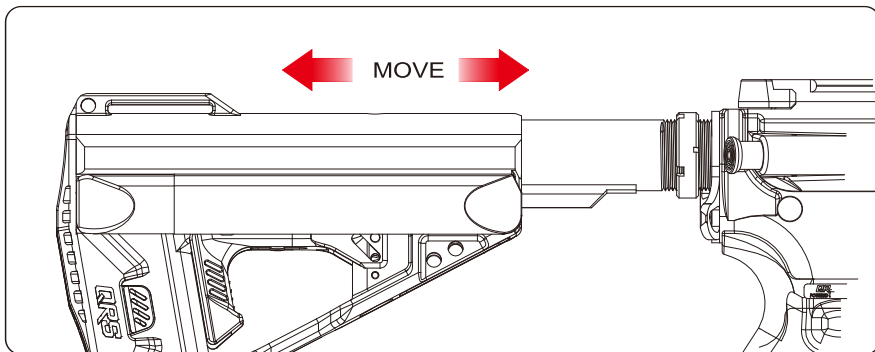

WARNING • CAUTION

- Be careful not to catch your fingers when operating buttstock functions. 在調整槍托位置時，請小心不要夾到手指。

CHARGING AND BOLT CATCH

CHARGING AND OPEN DUMMY BOLT 槍機拉柄與槍機飾片

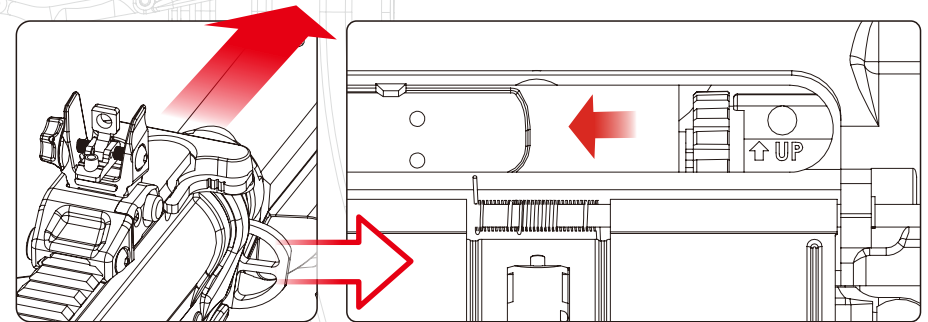

The charging handle can be pulled and the dummy bolt will remain open.
向後拉動槍機拉柄，槍機飾片打開。

RELEASE DUMMY BOLT 槍機飾片覆位

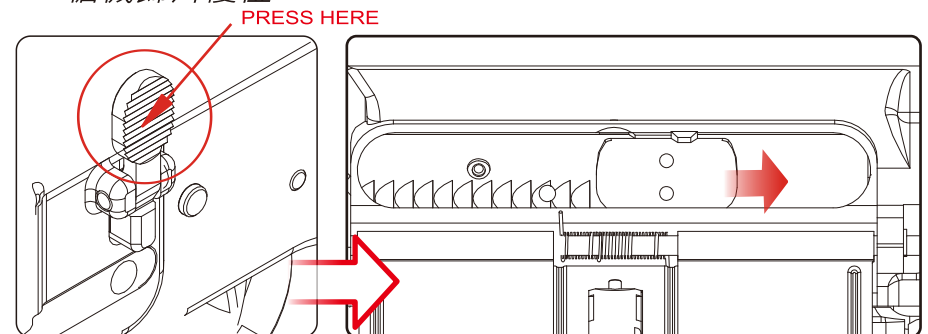

To Release bolt, just press the bolt catch.
按壓槍機釋放鈕，槍機飾片覆位。

Pinch Point Warning

Keep fingers out of bolt area when releasing bolt catch.
釋放槍機飾片時，請勿將手指放在槍機位置，以免夾到手指。

FIRING

Set the Selector lever to "SEMI" or "AUTO".
將射擊選擇鈕切換為 "單發" 或 "連發" 模式。

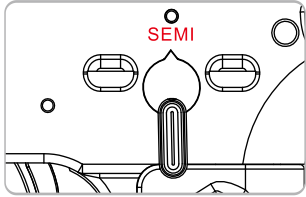

Semi Auto
半自動

Pulled the trigger,
the gun will fire one shot each time.
拉動一次扳機，則發射一發子彈

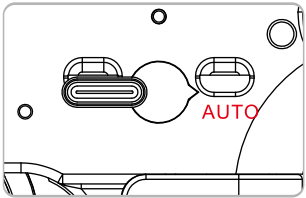

Full Auto
全自動

The gun will fire automatically
while the trigger remains pulled.
扣著扳機不放將連續發射子彈

WARNING • CAUTION

- Confirm selector is off SAFE before firing the gun.
確認射擊選擇鈕已經關閉保險後開始射擊。
- Pulling the trigger while the selector is on SAFE will damage the gun and cause it to malfunction.
當射擊選擇鈕切換為保險狀態時，扣壓扳機有可能導致故障。

CAUTION:
EYE PROTECTION
REQUIRED

WEAR YOUR
SHOOTING GLASSES

請注意
眼睛的保護

並於射擊時
戴上護目鏡

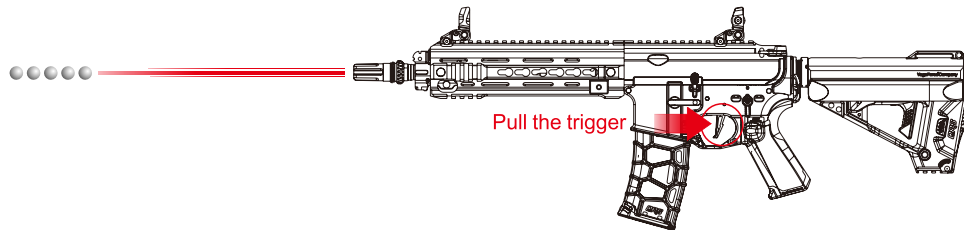

1. Set the selector lever to Semi-Auto or Full Auto.

將射擊選擇鈕切換為 "單發" 或 "連發" 模式。

2. Pull the trigger.

扣壓扳機，開始射擊。

CAUTION

Never put your finger on the trigger unless you are ready to shoot.
除準備射擊目標外，請不要將手指放在扳機上。

VARIABLE HOP-UP SYSTEM

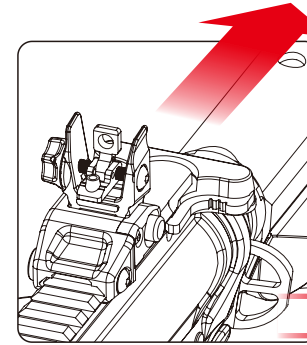

Your VR16 rifle comes standard with a variable hop-up system.
This hop-up system allows lift to be added to the bb's flight thus improving distance performance.
您的VR16步槍皆有配置HOP-UP調整系統。
HOP-UP有助於您調整彈道，改善射擊表現。

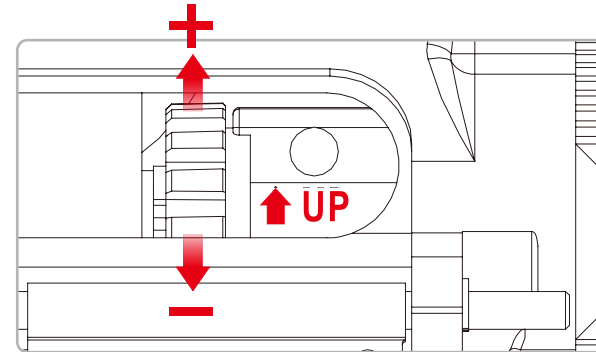
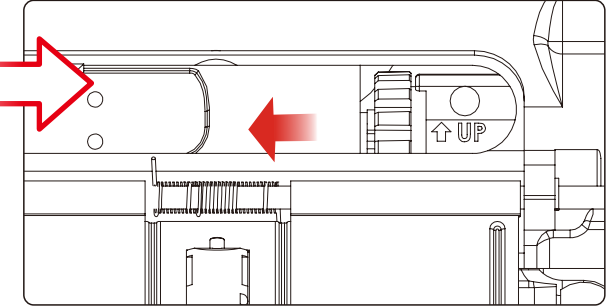

WARNING • CAUTION

- Too much hop up may cause BBs to jam.
If a jam occurs, immediately dial back the hop up and test fire again.
Otherwise, damaged and malfunctions will occur with the gun.

Hop 調整過度有可能造成 BB 彈卡彈。若發生卡彈現象請立即撥回撥盤並測試是否能夠射擊，過度調整 Hop 有可能造成損壞或故障。

- Open bolt to adjust the HOP-UP system.
打開槍機節片以調整HOP-UP系統。
- Gradually turn the adjustment dial in positive direction to increase hop up effect.
逐格將撥盤往 "+" 號方向轉動，以增加BB彈上旋效果。
- Turning excessively adversely affects the trajectory. So, stop turning the dial when bullets fly horizontally.
調整過度對彈道將有不良影響，因此，當BB彈彈道為水平飛行，請停止調整HOP。

MOD. VR16 INSTRUCTION MANUAL

Cal. 5.95mm Airsoft Electric Rifle

- The best position is where the bullets fly horizontally and the longest flying distance is obtained.
最佳彈道為BB彈水平飛行並獲得最長飛行距離。

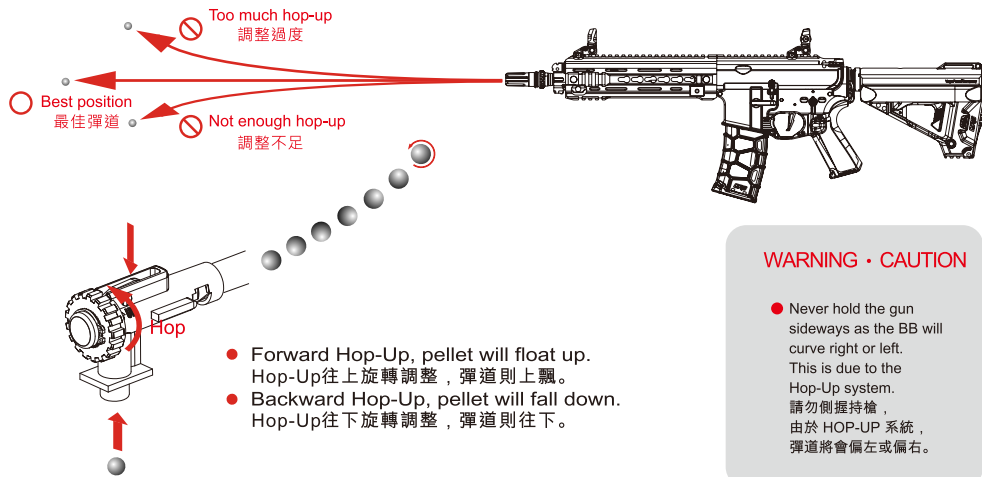

- Forward Hop-Up, pellet will float up.
Hop-Up往上旋轉調整，彈道則上飄。
- Backward Hop-Up, pellet will fall down.
Hop-Up往下旋轉調整，彈道則往下。

Improper Hop-Up Setting Troubleshooting

Symptom	Cause	Action
BB's flying upward BB彈飛行向上	Hop-up setting too high. Hop-up調整過度	Gradually return adjustment lever towards normal. 漸趨調節使彈道平穩正常
Short flying distance of BB's (less hop-up effect) BB彈飛行距離過短	Hop-up setting too high. Hop-up調整過度	Gradually return adjustment lever towards normal. 漸趨調節使彈道平穩正常
	Hop-up system contaminated by oil or dirt. Hop-up座內有灰塵或油汙	Clean using the cleaning rod or consult your dealer or VFC for repair. 清潔或連繫您的經銷商或VFC進行維修
	Worn or damaged Hop-up system. Hop-up座磨損或毀壞	Purchase the replacement part at your dealer or from VFC and replace it. 向經銷商或VFC購買替換零件替換
Can not adjust 無法調整	Damaged adjustment lever or other parts 調整環或其他零件損壞	Purchase the replacement part at your dealer or from VFC and replace it. 向經銷商或VFC購買替換零件替換
Frequent BB jamming BB彈頻繁阻塞	Hop-up setting too high. Hop-up調整過度	After the adjustment lever is returned to anormal side, and the hop is released, it adjusts again. 漸趨調節使彈道平穩正常
	Improper or too large sized BB's 使用不合適或太大的BB彈	Only use quality Airsoft BB's 使用優質BB彈
	Dirty Hop-up system Hop-up座內有髒汙	Clean using the cleaning rod or consult your dealer or VFC for repair 清潔或連繫您的經銷商或VFC進行維修

TROUBLESHOOTING CLINIC

Symptom	Cause	Action
No operation at all 無法動作	Selector lever is set to safety. 選擇鈕位於關保險位置	Set the selector lever to fire. 將射擊選擇扭轉至射擊模式
	Battery is not charged. 電池未充電	Charge the battery. 將電池充電
	Battery connector is disconnected. 電池接頭未連接	Connect the connector. 電池接頭確實連接
	The + and - of battery connector is reversed. 電池接頭正負極接反	Connect the connector correctly. 正確連接電極
	Fuse is blown out. 馬達老化(約5-6萬發)或接點不良	Replace the fuse. 更換馬達或修理接點。
Motor is cycling but gun does not fire 馬達有轉動但BB彈無法擊發	BB's are clogged inside the magazine. 彈匣內BB彈卡彈	Insert the charging cord into the magazine and move it up and down several times to remove jammed bb's 清除彈匣內的卡彈
	BB's are clogged in the chamber. 槍膛內BB彈卡彈	Remove jammed bb's in chamber using a cleaning rod. 清除槍膛內的卡彈
	Faulty gear. 齒輪損壞	Purchase the replacement gear from your dealer or VFC and repair. 向經銷商或VFC購買替換零件
Malfunction of full auto operation (automatic firing) 全自動射擊模式故障	Insufficient battery power. 電池電力不足	Charge the battery. 電池充電
	Faulty bb feed of connection. 彈匣給彈不良	Repair clogging of the magazine. 清除彈匣內的卡彈
Malfunction of semi-auto operation 半自動射擊模式故障	Poor electrical connection. 齒輪未正確歸位	Consult your dealer, VFC for maintenance or repair. 聯繫經銷商或VFC維修
Malfunction of semi-auto operation (single shot)單發 半自動射擊模式故障	Insufficient battery power. 電池電力不足	Charge the battery. 電池充電
	Poor electrical connection. 接點不良	Consult your dealer, VFC for maintenance or repair. 聯繫經銷商或VFC維修
Automatic firing cycles become slow 連射速度低落	Insufficient battery power. 電池電力不足	Charge the battery. 電池充電
Shooting distance becomes shorter 射程變短	Worn or damaged Hop-up system. Hop-up座磨損或毀壞	Consult your dealer, VFC for maintenance or repair.
	Worn or damaged piston packing.(O-ring) 氣筒O環磨損	Replace the chamber packing. piston packing(O-ring)and piston assembly.
	Deteriorated piston spring. 氣筒彈簧彈性疲乏	聯繫經銷商或VFC維修
	Faulty BB (too small or heavy) BB彈不良，大小或太重	Only use quality Airsoft BB's. 使用優質BB彈
	Shortage of Silicone oil. 矽油耗盡	Drop a few drops of silicone oil from under the chamber. 在槍膛添加數滴矽油
	Gear problems caused by excessive blank firing. 空擊太過造成齒輪異常	Consult your dealer, VFC for maintenance or repair.
Overly loud operating noise 動作聲音異常	Gear problems caused by excessive blank firing. 空擊太過造成齒輪異常	Replace the chamber packing. piston packing(O-ring)and piston assembly.
	Worn of damaged gear. 齒輪磨損或毀壞	聯繫經銷商或VFC維修
Bullets falling out from barrel end BB彈從槍口掉落	Gear problems caused by excessive blank firing. 空擊太過造成齒輪異常	Consult your dealer, VFC for maintenance or repair.
	Worn of damaged chamber packing. 槍膛橡皮磨損	Only use quality Airsoft BB's. 使用優質BB彈

V GAS

CORE POWER

PURITY QUALITY POWERFUL

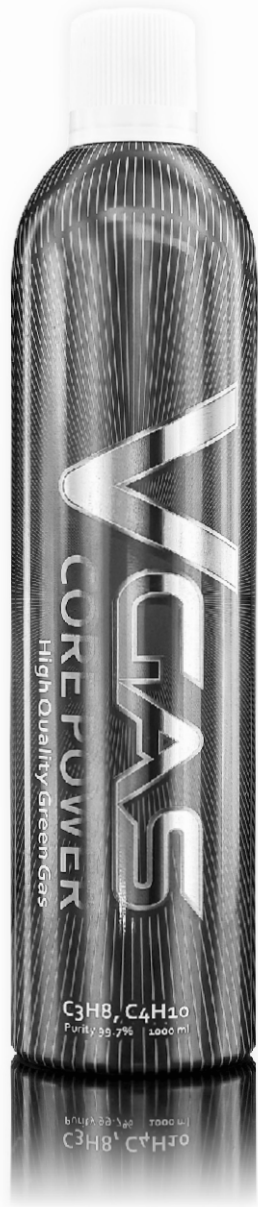

High Quality Green Gas
For Your Gas Rifle And Pistol
100% Made in Taiwan

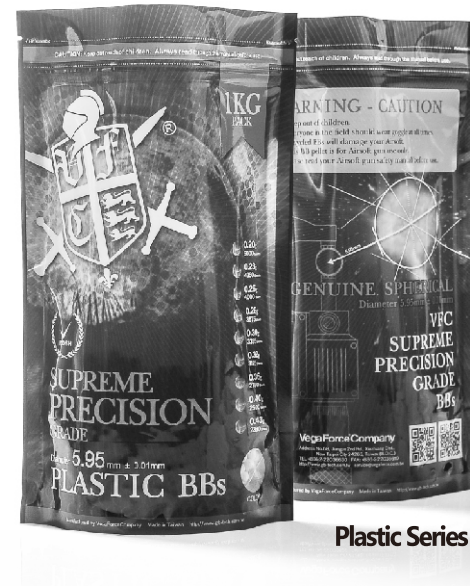

Plastic Series

**1KG
PACK**

SUPREME PRECISION GRADE BBs

For Your Gas Rifle And Pistol 100% Made In Taiwan

Diameter
5.95mm
± 0.01mm



CERTIFICATIONS:
Biodegradable Test Report ISO 14855-1 in connection with DIN EN 13432
Certified EN71 part 3:2013
Compliant with ASTM D-6400-99 "Standard Specifications for Compostable Plastics"

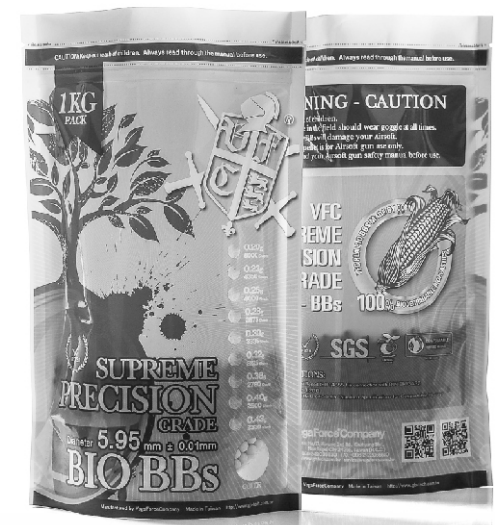

BIO Series